

SC-R-65-887

DESIGN FORMULAS FOR NONREACTIVE
HIGH-VOLTAGE PULSE RESISTORS

R. L. Davis

September 1965

First reprinting October 1968

Design Formulas for Nonreactive High-Voltage Pulse Resistors

R. L. DAVIS

Abstract—To terminate pulse equipment supplying peak voltages up to a million volts for microsecond durations requires nonreactive loads to maintain the pulse characteristics. The resistive elements must not only dissipate the pulse energy but must also maintain a low reactance for the high frequencies in the pulse waveform. The return circuit, treated as a short-circuited transmission line, forms the basis for designing nonreactive resistors with both cylindrical and flat conductors. The distribution of voltage, current, and power is shown for the ideal design. Formulas are derived for the Chaperon double winding, the "hairpin" or loop geometry, and the coaxial form. Resistance values range from less than an ohm to several hundred thousand ohms for pulse voltages up to 1.2 million volts. Time constants vary from 10^{-6} to 10^{-10} seconds. A frequency expression is derived to aid in predicting the resistor's frequency response. Construction and measuring techniques are included. Frequency effects are analyzed to compensate for the skin effect on the resistance and inductance, and to select low-loss dielectric materials.

Key Words (for Information Retrieval)—resistor design formulas, high-voltage pulse, nonreactive, wirewound.

INTRODUCTION

SINCE THE INCEPTION of radar, pulse applications of electronic components such as resistors and capacitors have continually increased. The design engineer must make allowances for the unknown part of the reactance of these components as well as the known values. This unknown reactance is especially true with resistors wherein the type of resistor determines its radio-frequency response. Normally, wire-wound resistors are considered to present inductive reactance, while carbon composition and film resistors have acceptable high-frequency responses. Still, for at least 60 years, the wire-wound resistor has been used in ac bridges to give controlled frequency responses of low reactance.¹

In "An Empirical Design for High-Voltage Pulse Resistors,"² the author described an experimental approach for making resistors for high voltages. These resistors, made with the Chaperon double winding, had low reactances. Since that time, a more extensive investigation has been made into known forms of resistors having low reactance and acceptable frequency responses.

This paper presents formulas and test results for resistors made from both cylindrical and ribbon conductors. The different geometries include the Chaperon winding, the loop or "hairpin," and the coaxial form. More than 200 units have been made for specialized Sandia Corporation equipment during the past three years.

Manuscript received October 24, 1964.

The author is with the Sandia Corporation, Albuquerque, N. M.

¹ F. W. Grover and H. L. Curtis, "The measurement of the inductance of resistance coils," *NBS Bul.*, vol. 8, pp. 455-485, 1912.

² Sandia Corp. Tech. Memo. SC-TM 230-62 (14).

PRINCIPLES OF TRANSMISSION LINES APPLIED TO PULSE RESISTORS

Historical Development of the Return Circuit

The basic principle for understanding the pulse resistor is the return circuit first studied by Kirchhoff in 1864. The circuit consists of two separated conductors in close proximity, with currents flowing in opposite directions. Ampere used the return circuit in his study of forces on conductors carrying currents and showed the magnetic field cancellation of the two currents. Maxwell extended this concept by applying his wave equations to the circuit for expressions of the inductance for cylindrical conductors, and suggested that ribbon wire would reduce the inductance indefinitely.³

Chaperon made the double winding in 1889, by which time constants of resistor coils of 10^{-8} seconds were produced. Heaviside extended Maxwell's work and set up the basis for electromagnetic waves guided by conductors. About 1895, C. P. Steinmetz of General Electric formulated the differential equation for the return circuit that relates the distributed parameters of resistance, inductance, and capacitance.⁴ Then, in 1908, E. B. Rosa and F. W. Grover, working at the U. S. Bureau of Standards, studied the formulas and extended the noninductive resistors for use in ac bridges.⁵ Since then, other authors have extended the basic concepts for particular problems.

The pulse resistor, being a form of the return circuit with continuous conductors, will conduct both dc and high-frequency currents. This feature predetermines that the electromagnetic pulse wave is a transverse one, with the components of both the electric and magnetic field being perpendicular to the direction of energy flow. This is the principle mode of transmission and offers the advantage of having no cutoff frequencies, which are present in other modes of transmission. Theoretically, the resistors would operate at extremely high frequencies except for changes taking place due to skin effect, reduction in the inductance, and losses in the dielectric material. However, by using high-resistivity conductors or thin films to reduce skin effect, by adjusting the inductance formulas for high frequencies, and by selecting an insulation with a stable dielectric constant and very low leakage, the frequency response of the resistor can be extended.

³ J. C. Maxwell, *A Treatise on Electricity and Magnetism*, vols 1., 2, 3rd ed. New York: Dover, 1954 reproduction of 1891 ed.; see vol. 2, ch. 13.

⁴ C. P. Steinmetz, *Theory and Calculation of Alternating Current Phenomena*, 3rd ed. Electrical World and Engineer, Inc., 1900.

⁵ H. L. Curtis and F. W. Grover, "Resistance coils for alternating current work," *NBS Bul.*, vol. 8, pp. 495-517, 1912.

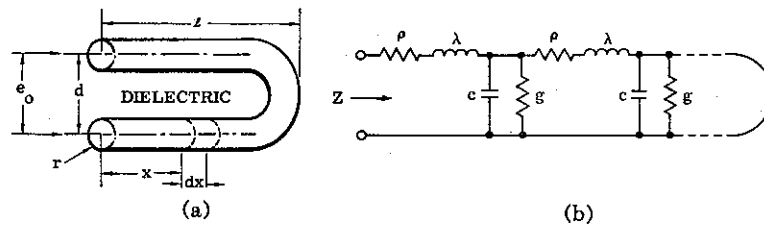

Fig. 1. Schematic and equivalent transmission line of the return circuit. (a) Schematic of return circuit; (b) equivalent transmission line.

Use of the return circuit does not restrict the resistance value, provided the correct geometry is selected. Any conducting material, such as silver or copper, can be applied, although a high-resistivity conductor is preferred.

The major difference between the ordinary transmission line and the pulse resistor is the value of the resistance. The ordinary transmission line requires the resistance to approach zero and to produce a lossless line. The pulse resistor, on the other hand, dissipates energy at the most efficient rate so that all of the energy of a pulse is dissipated by the time it reaches the end of the resistor. To do this, the distributed resistance, inductance, and capacitance must be interrelated in a definite way. The next section of this paper presents the relationship.

Mathematical Development Relating R , L , and C of the Resistor

F. K. Harris⁶ and B. Hague⁷ present the development of the return circuit for relating resistance, inductance, and capacitance so that a nonreactive resistor can be made for low frequencies. The main points are reproduced here to develop a higher-frequency expression and to apply the relations to different resistor geometries.

Figure 1 shows the schematic form of the return circuit and its equivalent transmission line with round wire. A flat ribbon conductor could have been shown as well.

In Fig. 1, l is the loop's length in centimeters; r is the conductor's radius in centimeters; d is the separation of the conductor's axes in centimeters, and is small compared to l ; x is any distance from the terminals along the conductors in centimeters; and ∂x is an elemental length of this transmission line. Also, we have:

- Z = input impedance
- ρ = resistance per unit length
- c = capacitance per unit length
- λ = inductance per unit length
- g = conductance per unit length

and

$$\omega = 2\pi f \text{ where } f \text{ is the frequency in cycles per second.}$$

Therefore,

$$\text{The total resistance is } R = l\rho$$

$$\text{The total capacitance is } C = lc$$

$$\text{The total inductance is } L = l\lambda$$

$$\text{The total conductance is } G = lg.$$

Across the element ∂x , we have a voltage

$$\partial e = (\rho + j\omega\lambda)i \partial x \quad (1)$$

and, by separating variables, we obtain

$$\frac{\partial e}{\partial x} = (\rho + j\omega\lambda)i. \quad (2)$$

Then, the elemental current flowing between the two conductors is

$$\partial i = (j\omega c + g)e \partial x \quad (3)$$

so that

$$\frac{\partial i}{\partial x} = (j\omega c + g)e. \quad (4)$$

Then, upon differentiating (2), we get

$$\frac{\partial^2 e}{\partial x^2} = (\rho + j\omega\lambda) \frac{\partial i}{\partial x}. \quad (5)$$

By substituting for $\partial i/\partial x$ from (4), we obtain

$$\frac{\partial^2 e}{\partial x^2} = (\rho + j\omega\lambda)(j\omega c + g)e = b^2 e \quad (6)$$

where

$$b = \sqrt{(\rho + j\omega\lambda)(j\omega c + g)}.$$

The solution for (6) is

$$e = C_1 \sinh bx + C_2 \cosh bx. \quad (7)$$

The boundary conditions for the pulse voltage applied to the terminals are a maximum at $x = 0$, and thereafter decrease to zero at the end of the return circuit where $x = l$. Substituting $e = e_0$ at $x = 0$, and $e = 0$ at $x = l$, we obtain

$$C_1 = \frac{e_0}{\tanh bl} \quad (8)$$

⁶ F. K. Harris, *Electrical Measurements*. New York: Wiley, 1959.

⁷ B. Hague, *Alternating Current Bridge Methods*, 5th ed. London: Pitman, 1946, chs. 2, 3.

and

$$C_2 = -C_1 \tanh bl \quad (9)$$

so that

$$e = e_0 \left(\cosh bx - \frac{\sinh bx}{\tanh bl} \right) \text{ volts} \quad (10)$$

and

$$i = \frac{1}{\rho + j\omega\lambda} \frac{\partial e}{\partial x} = \frac{e_0 b}{\rho + j\omega\lambda} \left(\sinh bx - \frac{\cosh bx}{\tanh bl} \right) \text{ amperes.} \quad (11)$$

Equations (10) and (11) are general expressions for any form of the return circuit and give the values of the voltage and current at any distance x from the terminals. Since we are striving to make the total impedance equal to the total resistance, to be developed in (14)–(28), we can simplify (11). When $Z = R$, the pulse voltage and current are in phase so that

$$i = \frac{e}{R} = \frac{e_0}{R} \left(\cosh bx - \frac{\sinh bx}{\tanh bl} \right) \text{ amperes.} \quad (12)$$

Also, the power becomes

$$p = \frac{e^2}{R} = \frac{e_0^2}{R} \left(\cosh^2 bx - \frac{2 \cosh bx \sinh bx}{\tanh bl} + \frac{\sinh^2 bx}{\tanh^2 bl} \right) \text{ watts.} \quad (13)$$

Figure 2 shows the variation of voltage, current, and power for an ideal pulse resistor, using the normalized value of e with an arbitrary value of 2 for R to separate the resulting values of current and power. Since bl has a convergence value of less than 1.57 ... [see (20)] for any particular resistor, a value of 1 was selected, thereby limiting the variation of bx between 0 and 1.0. The graphs show that peak values of the pulse voltage, current, and power occur at the high-potential end of the resistor, and then decrease exponentially to zero.

The graphs point out an important feature of the pulse resistor: if a voltage breakdown occurs, it will be located at the beginning of the conductors where the voltage, current, and power are maximums. This feature has been demonstrated by actual units described in the Sandia Memorandum.² Figure 3 shows a typical breakdown beginning at the high-potential end of the resistor.

Now, proceeding to the expression for the impedance of the return circuit, we have for the current at $x = 0$ from (11)

$$i|_{x=0} = i_0 = -\frac{e_0 b}{(\rho + j\omega\lambda) \tanh bl} \quad (14)$$

Therefore, the input impedance becomes, in the absolute value,

$$Z = \left| \frac{e_0}{i_0} \right| = \frac{(\rho + j\omega\lambda)}{b} \tanh bl. \quad (15)$$

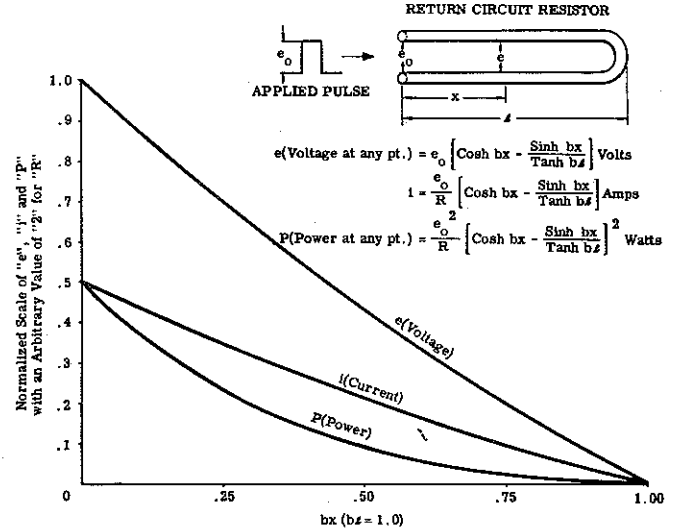

Fig. 2. Plots of pulse voltage, current, and power for the ideal pulse resistor.

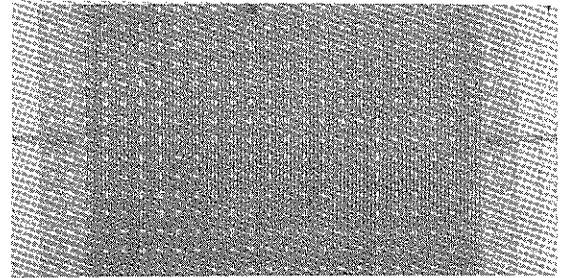

Fig. 3. Breakdown at 600 kilovolts. (Progressive breakdown of pulse resistor at 600 kilovolts after 100 discharges. Resistance value of 275 ohms.)

We can also derive this same expression from the general expression for the impedance of a transmission line⁸

$$Z_s = Z_0 \left(\frac{Z_r + Z_0 \tanh bl}{Z_0 + Z_r \tanh bl} \right) \quad (16)$$

where

- Z_s = input impedance
- Z_0 = characteristic impedance
- Z_r = load impedance.

Making $Z_r = 0$ for our case, we obtain

$$Z_s = Z_0 \tanh bl. \quad (17)$$

Z_0 is $\sqrt{(\rho + j\omega\lambda)l / (j\omega c + g)l}$, and by multiplying the numerator and denominator by $\sqrt{(\rho + j\omega\lambda)}$, we get

$$Z_0 = \sqrt{\frac{(\rho + j\omega\lambda)^2}{(j\omega c + g)(\rho + j\omega\lambda)}} = \frac{\rho + j\omega\lambda}{b} \quad (18)$$

since b is $\sqrt{(\rho + j\omega\lambda)(j\omega c + g)}$ from (6).

⁸ L. A. Ware and H. R. Reed, *Communications Circuits*, 2nd ed. New York: Wiley, 1947, chs. 1, 5, 6, app. III.

Therefore, substituting this expression for Z_0 in (17), we have

$$Z_s = \frac{\rho + j\omega\lambda}{b} \tanh bl \quad (19)$$

which is the same expression for Z given in (15).

Upon expanding $\tanh bl$, we have⁹

$$\tanh bl = bl - \frac{b^3 l^3}{3} + \frac{2}{15} b^5 l^5 - \frac{17}{315} b^7 l^7 + \dots \quad (20)$$

which is convergent for $|bl| < \pi/2$.

Substituting in (19), we have

$$Z = \frac{\rho + j\omega\lambda}{b} \left[bl - \frac{b^3 l^3}{3} + \frac{2}{15} b^5 l^5 - \frac{17}{315} b^7 l^7 + \dots \right] \quad (21)$$

Factoring l out of the brackets and multiplying by $1/b$ into the brackets, we obtain

$$Z = (\rho + j\omega\lambda) \cdot l \left[1 - \frac{b^2 l^2}{3} + \frac{2}{15} b^4 l^4 - \frac{17}{315} b^6 l^6 + \dots \right] \quad (22)$$

By substituting $R = \rho l$, $L = \lambda l$, $C = cl$, $G = gl$, and $b = \sqrt{(\rho + j\omega\lambda)(j\omega C + G)}$ we get

$$Z = (R + j\omega L) \left[1 - \left(\frac{1}{3} R + j\omega L \right) (j\omega C + G) + \frac{1}{15} (R + j\omega L)^2 (j\omega C + G)^2 - \frac{17}{315} (R + j\omega L)^3 (j\omega C + G)^3 + \dots \right] \quad (23)$$

which is the general expression for the resistor's impedance in terms of the total resistance, inductance, capacitance, leakage, and frequency. In its present form the expression is quite difficult to manipulate. If we expand the terms and make some simplifying assumptions, we can obtain expressions for making the resistor nonreactive.

By removing the brackets in (23), we have

$$Z = (R + j\omega L) - \frac{1}{3} (R + j\omega L)^2 (j\omega C + G) + \frac{1}{15} (R + j\omega L)^3 (j\omega C + G)^2 - \frac{17}{315} (R + j\omega L)^4 (j\omega C + G)^3 + \dots \quad (24)$$

If $R \gg \omega L$, ωC , and $G = 0$ in all terms above the first, we obtain

$$Z = R + j\omega L - \frac{1}{3} R^2 \cdot j\omega C + \frac{1}{15} R^3 (-\omega^2 C^2) - \frac{17}{315} R^4 (-j\omega^3 C^3) + \dots \quad (25)$$

Collecting the real and imaginary terms, we have

$$Z = \left(R - \frac{1}{15} R^3 \omega^2 C^2 \right) + j\omega \left(L - \frac{1}{3} R^2 C + \frac{17}{315} R^4 \omega^2 C^3 \right) + \dots \quad (26)$$

If the terms containing R^3 and R^4 are dropped, since they are small compared to unity up to 10 megacycles, we obtain

⁹ T. S. Peterson, *Elements of Calculus*. New York: Harper, 1950, p. 265, problem 44.

$$Z = R + j\omega \left(L - \frac{R^2 C}{3} \right) \quad (27)$$

This is the expression that Harris and Hague obtained for making a resistor nonreactive at low frequencies, a few kilocycles.⁷ To make the resistor nonreactive, i.e., $Z = R$, the expression within the parentheses must be zero. Hence,

$$L - \frac{CR^2}{3} = 0 \quad (28)$$

and

$$L = \frac{R^2 C}{3} \quad \text{or} \quad R = \sqrt{\frac{3L}{C}} \quad (29)$$

Upon substituting expressions for L and C for different resistors, we can design resistors in terms of the dielectric material and the conductors' geometries. It must be remembered that the formulas for L and C must be based upon a unit length and not upon the coils' configuration. The mode of winding the conductors does not affect the distribution of the inductance and capacitance as long as the separation and size of the conductors are maintained throughout the lengths. Although the expression becomes limited as ωL and ωC approach R , we have a useful relation. It has been used by several authors.^{5,7}

The relation in (28) may be written

$$\pm (\text{residual } L \text{ or } C) = L - (CR^2/3) \quad (30)$$

The sign of the residual L or C determines whether the resistor is inductive or capacitive. A positive value is inductive and a negative is capacitive. The $CR^2/3$ term controls the sign for large values of R and C , while L determines the sign for small values of R .

Dividing the expression by R , we obtain

$$\pm \left(\frac{\text{residual } L \text{ or } C}{R} \right) = \frac{L}{R} - \frac{CR}{3} \quad (31)$$

showing the time constant of the resistor to be the difference of the time constants of the geometrical inductance and the capacitance. When a resistor's reactance is measured at any frequency, it is the value of the residual reactance that is obtained. It can be a parallel reactance or its equivalent series value. Normally, it is considered a series inductance or a parallel capacitance. The phase angle becomes

$$\tan^{-1} \omega \left(\frac{L}{R} - \frac{CR}{3} \right)$$

Therefore, the equivalent circuit of the resistor at a particular frequency can be any one of the three indicated in Fig. 4.

To obtain an expression for higher frequencies, we expand the series of (24) to six terms as shown in (107), Appendix I, and obtain

$$Z = R \left[1 + 2\omega^2 C \left(\frac{L}{3} - \frac{R^2 C}{15} \right) + j\omega \left[L + \frac{1}{3} \omega^2 L^2 C - \frac{1}{3} R^2 C \right] \right] \quad (32)$$

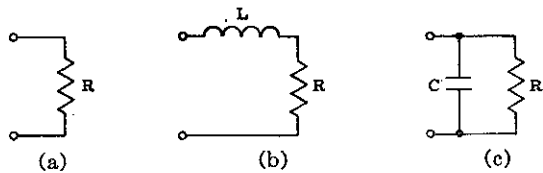

Fig. 4. Equivalent circuit of pulse resistor. (a) Ideal; (b) inductive; (c) capacitive.

Setting the reactive term equal to zero and solving for R , we get

$$R = \sqrt{\frac{L}{C} (3 + \omega^2 LC)}. \quad (33)$$

Also by making the expression $(L/3 - R^2 C/15)$, in the parentheses of the real part, zero in (32), we obtain

$$R = \sqrt{\frac{5L}{C}}, \text{ or residual reactance} = L - \frac{CR^2}{5}, \quad (34)$$

similar to (30). Both of these relations for R are equal when

$$\omega^2 LC = 2 \quad \text{or} \quad f = \frac{1}{\pi} \sqrt{\frac{1}{2LC}}. \quad (35)$$

This expression is an approximate resonant frequency controlled by the related values of R , L , and C . The frequency expression is twice that for a normal resonant tank circuit, where $\omega^2 LC = 1$. It is not expected that the frequency value for a particular resistor will mark a dramatic change in the resistor's frequency response. However, the larger this frequency is, the wider will be the frequency response of the resistor.

By substituting formulas for L and C , we can obtain an upper frequency expression to help predict the frequency response in terms of the geometry of the conductors and the dielectric material.

By making $R = \sqrt{5L/C}$, the resistive portion will remain constant. The reactive part will be slightly negative (i.e., capacitive) at low frequencies, depending upon the value of $\omega^2 LC$. Then it will decrease to zero at $f = 1/\pi \sqrt{1/2LC}$. Above this frequency, the reactive component tends to become positive, i.e., inductive. At still higher frequencies, the resistance value decreases and the residual reactance becomes more and more capacitive since the losses increase. (See section on *Frequency Effect on the Dielectric Material*.) The frequency response curves shown in Fig. 9 demonstrate these basic features. Figure 23 is an example of units that are inductive at low frequencies and then have peaks in both the resistive and reactive components at higher frequencies.

We can obtain more terms of the expansion given in (112), Appendix I, and have

$$Z = R \left[1 + 2\omega^2 C \left(\frac{L}{3} - \frac{R^2 C}{15} + \frac{\omega^2 L^2 C}{5} \right) \right] + j\omega \left[L - R^2 \left(\frac{C}{3} + \frac{2}{5} \omega^2 LC^2 \right) + \omega^2 L^2 C \left(\frac{1}{3} + \frac{1}{15} \omega^2 LC \right) \right]. \quad (36)$$

Although one might feel that more terms will further aid in analyzing the impedance, there are other factors to consider. Some of these are:

- 1) The inductance decreases with increasing frequency, since the current is redistributed in the conductors because of the "skin effect."
- 2) The capacitance changes with increasing frequency, since the dielectric constant of the dielectric decreases, and losses increase.
- 3) The resistance increases at higher frequencies because the current becomes confined to the surface of the conductors.

Therefore, we see that all the terms are functions of frequency, which makes the analysis very difficult. But we can compensate for these frequency effects by using:

- 1) Formulas derived for high frequencies, to compensate for the change in the distributed inductance.
- 2) Dielectrics having stable dielectric constants and low losses for a wide frequency range, to aid in making a more predictable resistor.
- 3) Conductors having high resistivities, to reduce the skin effect.

Before discussing these items in detail in the section, "Frequency Effects," we should study the different resistor geometries and obtain a measure of their frequency responses. This is the topic of the next section of this paper.

DESIGN FORMULAS FOR PULSE RESISTORS OF DIFFERENT GEOMETRIES

The Chaperon Winding Using Round Wire

Figure 5 shows the Chaperon winding where currents flow in opposite directions in the two coils. After viewing a small section of the double winding, we can indicate the geometrical dimensions for controlling the resistor's reactance (Fig. 6). The inductance of the winding is¹⁰

$$L = 4l \left(\ln \frac{d}{r} + \frac{1}{4} \right) \cdot 10^{-9} \text{ henries} \quad (37)$$

and the capacitance is⁸

$$C = \frac{Kl \cdot 10^{-12}}{3.6 \ln \frac{d}{r}} \text{ farads} \quad (38)$$

where

- l = length of one winding in centimeters
- d = distance between centers of the conductors in centimeters
- r = radius of the conductors in centimeters
- k = dielectric constant of both the insulation on the wires and the dielectric between them, and
- \ln = logarithm to the natural base of 2.718...

¹⁰ *Formulas and Tables for the Calculation of Mutual and Self-Inductance (Revised)*, No. 169, Scientific Papers of Bureau of Standards, 3rd Ed., 1948, pp. 150-188.

If we substitute these expressions in $R = \sqrt{3L/C}$ for low frequencies, we obtain

$$R = \frac{208}{\sqrt{K}} \sqrt{\left(\ln \frac{d}{r}\right)^2 + \frac{1}{4} \ln \frac{d}{r}} \text{ ohms.} \quad (39)$$

For the high-frequency expression, $R = \sqrt{5L/C}$, we find

$$R = \frac{268.5}{\sqrt{K}} \sqrt{\left(\ln \frac{d}{r}\right)^2 + \frac{1}{4} \ln \frac{d}{r}} \text{ ohms.} \quad (40)$$

In Fig. 7, plots of R versus d/r are shown for values of $d/r > 10$. If d/r is less than 10, we must change the spacing formula to accommodate the proximity effect of the conductors. The expression $\ln(d/r)$, is derived from the more complete expression,^{7,11}

$$\ln \left[\frac{d}{2r} + \sqrt{\left(\frac{d}{2r}\right)^2 - 1} \right] \quad (41)$$

which is equivalent to

$$\cosh^{-1} \frac{d}{2r} \quad (42)$$

Substituting in the high-frequency equation for the resistance, we have

$$R = \frac{268.5}{\sqrt{K}} \sqrt{\left(\cosh^{-1} \frac{d}{2r}\right)^2 + \frac{1}{4} \cosh^{-1} \frac{d}{2r}} \text{ ohms.} \quad (43)$$

In Fig. 8 a plot for (43) is shown for two different values of k .

In both (40) and (43) it should be observed that the value of R is not a function of the length of the conductors. Thus, the relation among R , L , and C for a nonreactive resistor is maintained per unit length of the Chaperon or double winding. However, the spacing of the paired conductors must be precisely controlled throughout the windings to obtain the best frequency response. Both plots in Fig. 7 and 8 show that a small change in the ratio d/r produces a large change in the resistance value.

Using the expression, $f = 1/\pi \sqrt{1/2LC}$, for the predictable frequency of the Chaperon winding, we substitute (37) and (38) for L and C . For any value of the ratio of $d/r > 10$, we obtain

$$f = \frac{6.72 \cdot 10^9}{l\sqrt{K}} \frac{\sqrt{\ln \frac{d}{r}}}{\sqrt{\ln \frac{d}{r} + \frac{1}{4}}} \text{ cycles per second.} \quad (44)$$

For proximity effects, $\cosh^{-1}(d/2r)$ is substituted for $\ln(d/r)$. Since $l = 2R/\rho$ for the double winding, and ρ is the resistivity in ohms per centimeter, we have

$$f = \frac{3.36 \cdot \rho \cdot 10^9}{R\sqrt{K}} \frac{\sqrt{\ln \frac{d}{r}}}{\sqrt{\ln \frac{d}{r} + \frac{1}{4}}} \text{ cycles per second.} \quad (45)$$

¹¹ A. D. Kraus, "Hyperbolic functions," *Electro-Technology*, vol. 68, pp. 87-92, October 1961.

From this expression, we see that the resistivity of the wire should be as high as possible, such as that used in wirewound resistors, having a value of 800 ohms per circular mil foot (26.5 ohms per centimeter). Also, the wire size should be as small as possible for the best frequency response. However, large pulse currents force a compromise and the optimum size cannot always be used. The value of K should be the value measured in the vicinity of the estimated frequency.

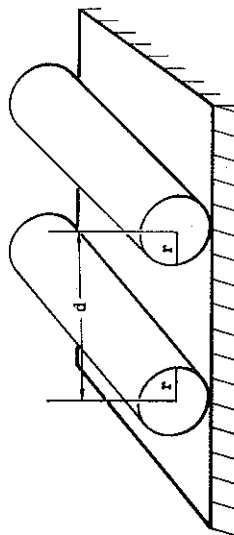

Fig. 6. Geometrical dimensions controlling the reactance of the Chaperon winding.

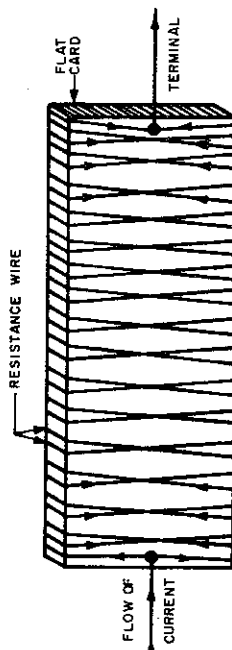

Fig. 5. The Chaperon winding.

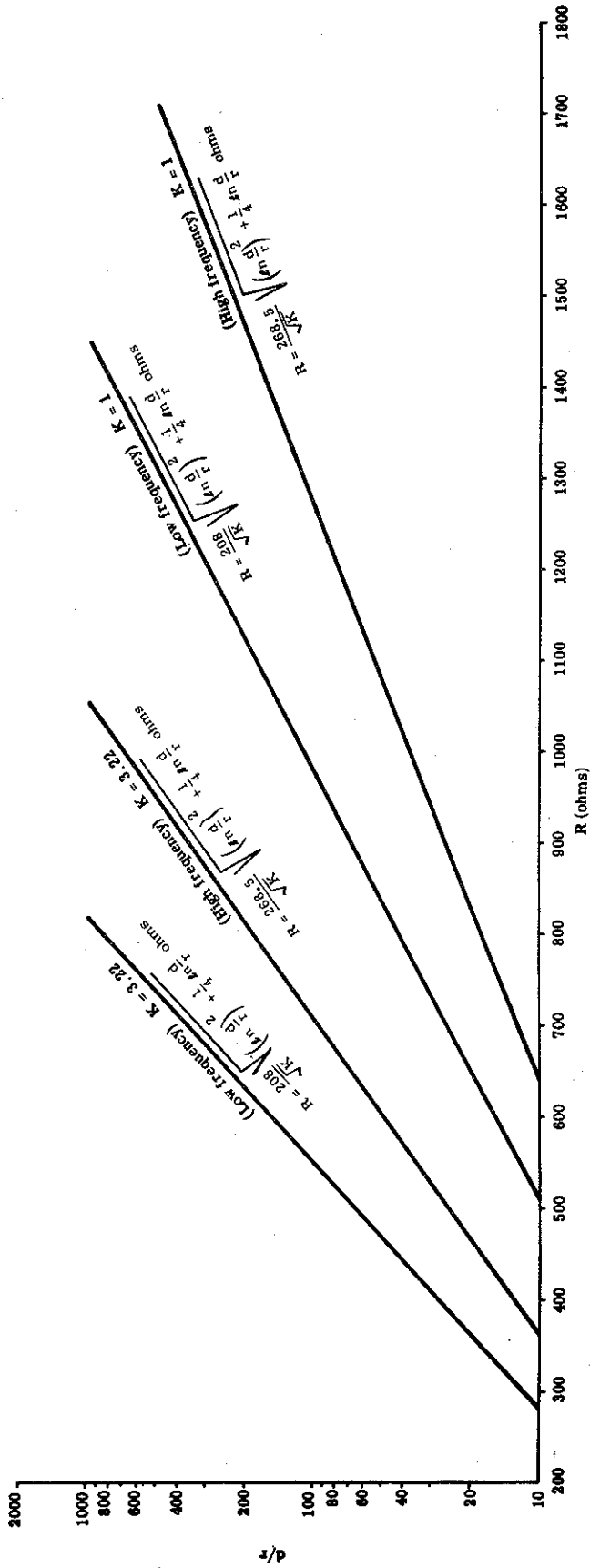

Fig. 7. Plots of formula for resistance of Chaparon winding to produce nonreactive resistors for d/r greater than 10.

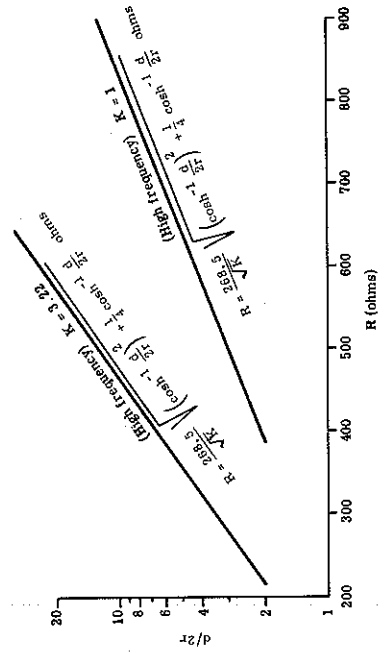

Fig. 8. Plots of formula for resistance of Chaparon winding to produce nonreactive resistors for values of $d/2r$ of 10 or less.

Table I lists the constructional and frequency data on several Chaperon resistors, using round wire, made on both flat cards and cylindrical cores. The constructional data include the wire size, resistance per unit length, and the turns per inch for each winding. The frequency data show the actual ratio of d/r for each resistor and the theoretical values taken from Fig. 7, or calculated from (40). The time constants were calculated from measurements at different frequencies. The predicted frequency,

using (45), is listed for each resistor. All of the resistors were encapsulated in SRIR epoxy (Semi-Rigid Inspection Resin developed for pulse transformers), which has a dielectric constant of 3.22 at 10 megacycles.

The theoretical value of d/r was not used because the pulse current required larger wires and because of restrictions imposed upon the physical dimensions of the resistors. Thus, the resistors are predominantly capacitive since the dc resistance exceeds the theoretical value

TABLE I
CHAPERON PULSE RESISTORS USING ROUND WIRE

Sample No.	Resistance value (ohms)	Peak voltage (kilovolts)	Wire size (inch)	Resistance of wire (ohms/cms)	Predicted frequency (cps)	Turns per inch	$\frac{d}{r}$ Actual	$\frac{d}{r}$ Calculated	Time constant (seconds) from measurements at frequency (megacycles)
1	15 K	100	0.0014	13.2	$1.65 \cdot 10^6$	52	25.7	2.9×10^{43}	$-4.2 \cdot 10^{-8}$ @ 1 mc
2	1 K	100	0.005	1.075	$2.15 \cdot 10^6$	16.1	25	630	$-8.7 \cdot 10^{-10}$ @ 0.2 mc $-2.6 \cdot 10^{-9}$ @ 1 mc $-5.05 \cdot 10^{-9}$ @ 50 mc
3	2 K	100	0.005	1.075	$1.07 \cdot 10^6$	33.6	11.8	5.3×10^5	$-6.2 \cdot 10^{-9}$ @ 0.2 mc $-9.8 \cdot 10^{-9}$ @ 1 mc $-9.8 \cdot 10^{-9}$ @ 50 mc
4	10 K	100	0.0031	2.8	$5.25 \cdot 10^6$	62.4	10.3	8×10^{20}	$-4.2 \cdot 10^{-8}$ @ 0.2 mc $-6.2 \cdot 10^{-8}$ @ 1 mc $-4.8 \cdot 10^{-8}$ @ 50 mc
5	50 K	150	0.0014	13.2	$4.96 \cdot 10^5$	64.3	20.7	2.6×10^{136}	$-2.15 \cdot 10^{-7}$ @ 0.2 mc $-3.0 \cdot 10^{-7}$ @ 1 mc $-2.2 \cdot 10^{-7}$ @ 50 mc
6	500	100	0.010	0.263	$9.9 \cdot 10^5$	33	6.06	26	$+1.8 \cdot 10^{-6}$ @ 0.2 mc $+3.7 \cdot 10^{-6}$ @ 1 mc $-2.6 \cdot 10^{-9}$ @ 50 mc
7	50 K	500	0.0014	13.2	$4.96 \cdot 10^5$	83.6	16	2.6×10^{136}	$-4.8 \cdot 10^{-7}$ @ 0.2 mc $-4.3 \cdot 10^{-7}$ @ 1 mc $-5.3 \cdot 10^{-7}$ @ 50 mc

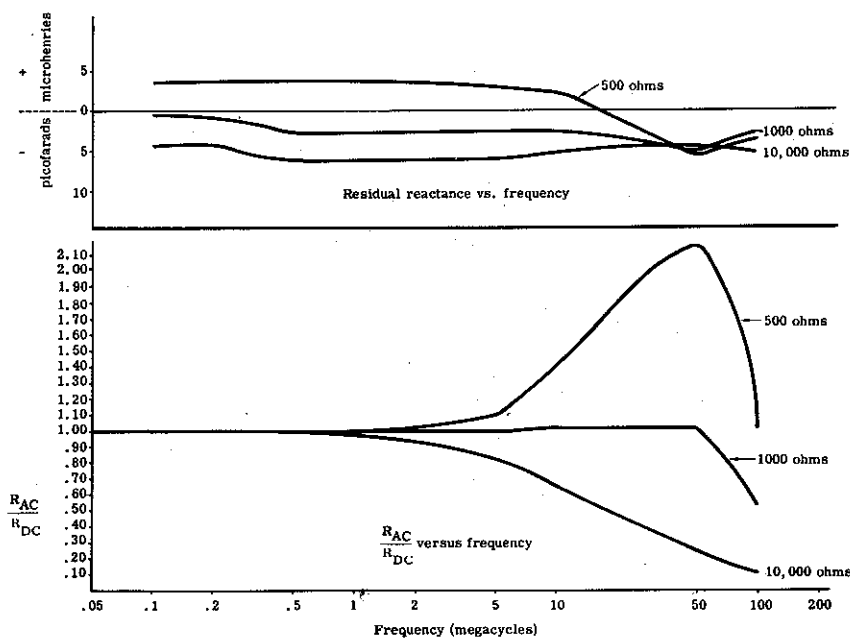

Fig. 9. Frequency responses of 500-, 1000- and 10000-ohm resistors listed in Table I.

corresponding to the actual ratio of d/r . Although the ratio for the 500-ohm unit approached the theoretical value, the resistor remained inductive. It must be remembered that the predictable frequency formula is not valid, since the resistors were not built in accordance with the value of d/r . Still, the formula provides an estimate of the frequency response.

The time constant of a resistor is not always the best indicator of its frequency response. Although it may be a low value, it does not indicate the change in the ac resistance value with frequency. It does show that the residual reactance is 1) inductive or capacitive by its sign, 2) changing or not changing with frequency, and 3) sufficiently small so that it will not affect the rise time of the pulse's leading edge. To apply the resistor fully, one must also consider its frequency response.

The frequency response of the 500-, 1000-, and 10000-ohm unit is shown in Fig. 9. The ratio, R_{AC}/R_{DC} , is plotted at each frequency in the lower part of the figure; the corresponding inductive or capacitive residual reactance is shown in the upper portion.

The plots show that the 1000-ohm resistor has the best frequency response for the resistance value and residual reactance. This result is normally found with 1000-ohm values of the Chaperon winding unless an extremely large resistor is made. The stability of the resistance value with frequency exceeded the estimated upper frequency.

The 10000-ohm unit has the characteristic frequency response of a large resistance value when the two windings are close together and consist of many turns. The estimated frequency coincides with the frequency at which the resistance value begins to decrease. To improve the frequency response requires either that the d/r ratio be extremely large, or that smaller wire be used so that both the distributed inductance and capacitance are reduced.

The 500-ohm resistor demonstrates its inductive properties with the increase in the ac resistance above its predicted frequency of one megacycle. Then, the resistance decreases rapidly above 50 megacycles. However, the inductive reactance changed to a capacitive value at 10 megacycles. These properties show that the real part of the total impedance (ac resistance) and the imaginary portion (residual reactance) can change independently of each other. Resistors, having a very low residual reactance, show a more consistent relation between the two components (see Fig. 15). To improve the frequency response, one must use ribbon conductors so that the capacitance is increased and the inductance is decreased. The use of ribbon conductors is described in the next section.

Figures 10-13 are photographs of different Chaperon resistors showing various constructional features.

The data on the resistors having the Chaperon winding with round wire applies directly to the noninductively wound resistors commercially available. These units of

relatively small size are wound on ceramic cores and then encapsulated in a silicone protective covering.

Since they are small, short lengths of wire must be used to produce their limited resistance range. Thus, both the total inductance and capacitance are reduced. The resistance value essentially controls the residual reactance. Below 1000 ohms, the resistors tend to be inductive, and above 1000 ohms they are capacitive. Units of 1000 ohms are essentially nonreactive.

Figure 14 is a photograph of four different sizes of 1000-ohm resistors. All of them have extremely low reactances up to 100 megacycles. Figure 15 shows the frequency response of the largest and smallest units. The lead lengths of the smallest unit were adjusted to make its reactance zero as shown in the photograph.

Since the single units have such low reactances, they can be connected in strings to produce high-voltage pulse resistors. Such a unit is shown in Figure 16. This resistor consists of five small resistors, 5-watt size, each having 10000 ohms resistance. The encapsulated unit with its corona shields readily operated at the 50-kilovolt rating. Another unit, not shown consisted of six resistors of the 10-watt size, totaling 110 kilohms. It withstood a 500-kilovolt, 10-microsecond pulse repeatedly.

The Chaperon Winding Using Wire Ribbon

If ribbon or tape conductors are used in place of round wire, the capacitance is increased and the inductance is decreased for the same resistance value. Thus, tapes are used mostly for the low resistance values. However, they can be used for higher resistance values if the tapes are separated sufficiently.

To use tape conductors, one must consider how the tapes are wound in regard to their separation. Figure 17 shows three situations that must be considered.

For the arrangement in Fig. 17(a) the inductance is¹⁰

$$L = 4l \ln \frac{R_2}{R_1} \cdot 10^{-9} \text{ henries} \quad (46)$$

where l = length of one tape in centimeters

$$\ln R_1 = \ln b - (3/2),$$

where b is the width of the tapes in centimeters

$$\ln R_2 = \frac{d^2}{b^2} \ln d + \frac{1}{2} \left(1 - \frac{d^2}{b^2} \right) \ln (b^2 + d^2) + \frac{2d}{b} \tan^{-1} \frac{b}{d} - \frac{3}{2}$$

d = separation between tapes in centimeters.

The expressions for R_1 and R_2 were developed by Maxwell for the geometrical mean distance of one tape from itself, and two tapes in parallel, shown in Fig. 18.^{1,10,12}

¹² F. W. Grover, *Inductance Calculations Working Formulas and Tables*. New York: Dover, 1962, chs. 2, 3, 5, 6, 24.

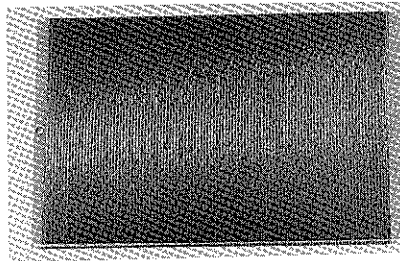

Fig. 10. A 200-ohm Chaperon resistor prior to attaching terminals and encapsulating in epoxy for 100-kilovolt operation.

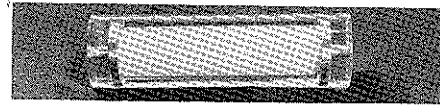
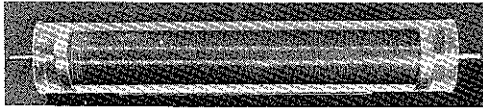

Fig. 11. A 600-ohm, 1.2 million-volt, Chaperon resistor with corona shields encapsulated in epoxy resin.

Fig. 12. A 35-kilohm, 100-kilovolt, Chaperon resistor with corona shields encapsulated in epoxy resin.

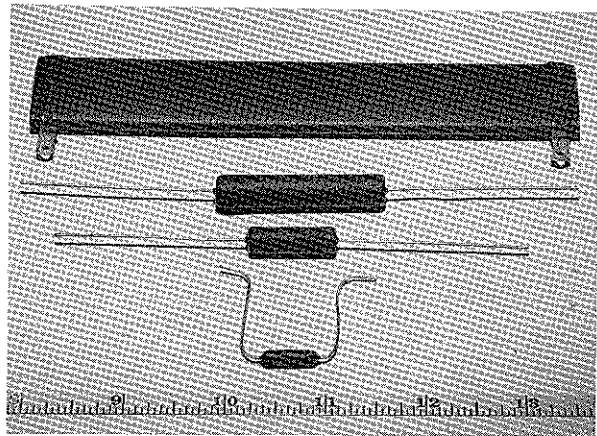
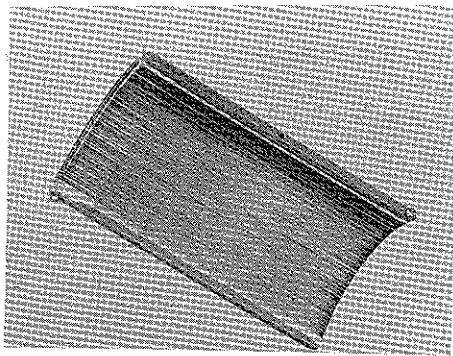

Fig. 13. A 50-kilohm, 150-kilovolt, Chaperon resistor wound on a curved card prior to being mounted and encapsulated in epoxy resin.

Fig. 14. Four different wattage sizes of MIL-R-26 type resistors of 1000-ohm resistance wound in the Chaperon manner.

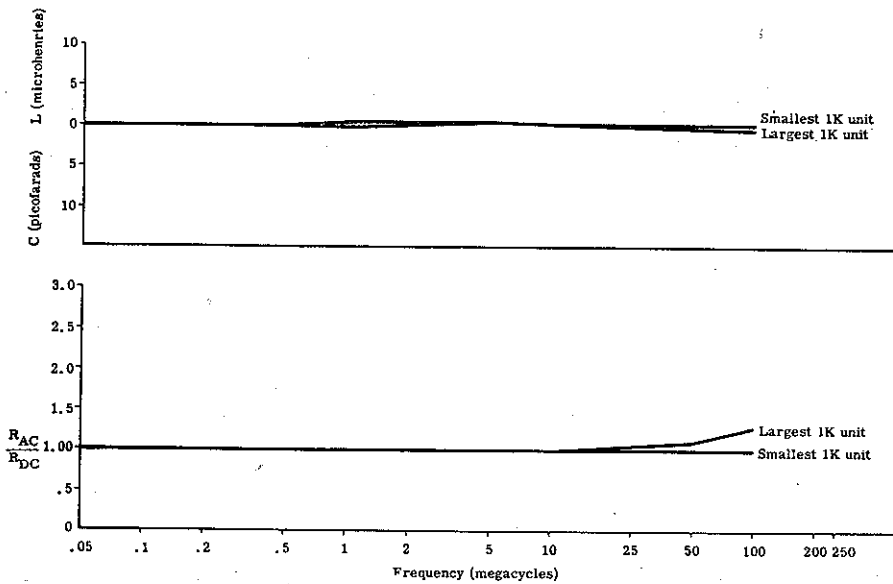
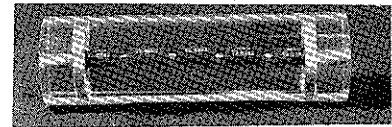

Fig. 15. Frequency response of the largest and smallest 1000-ohm resistors shown in Fig. 14.

Fig. 16. A 50-kilovolt pulse resistor consisting of five 10-kilohm, 5-watt, Chaperon-wound resistors.



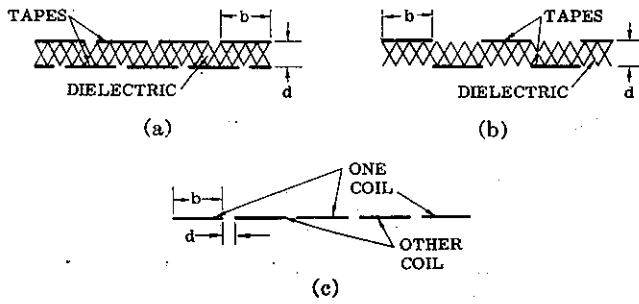

Fig. 17. Possible tape configurations. (a) Closely wound tapes, one coil inside the other. (b) Widely separated tapes, one coil inside the other. (c) Tapes of both coils in the same plane. b = width of tape; d = separation of tapes of the two coils.

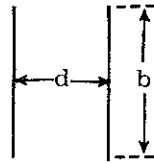

Fig. 18. Parallel tapes of negligible thickness.

The capacitance of these tapes, considered as plates of a capacitor, is¹³

$$C = \frac{8.85Klb}{d} \cdot 10^{-14} \text{ farads} \quad (47)$$

where K = dielectric constant of material between the tapes, and l , b , and d are the same for the inductance expression. Substituting the expression for L and C into the low-frequency expression for R , we obtain

$$R = \frac{368}{\sqrt{K}} \sqrt{\frac{d}{b}} \ln \frac{R_2}{R_1} \text{ ohms.} \quad (48)$$

For the high-frequency expression, $R = \sqrt{5L/C}$, we obtain

$$R = \frac{475}{\sqrt{K}} \sqrt{\frac{d}{b}} \ln \frac{R_2}{R_1} \text{ ohms.} \quad (49)$$

The plot of R versus d/b is shown in Fig. 19 for both expressions of R .

The predictable frequency from $f = 1/\pi \sqrt{1/2LC}$ becomes

$$f = \frac{1.195 \cdot 10^{10}}{l\sqrt{K}} \cdot \sqrt{\frac{d}{b \ln \frac{R_2}{R_1}}} \text{ cycles per second.}$$

In Fig. 17(c), the inductance is¹⁰

$$L = 4l \ln \frac{R_2}{R_1} \cdot 10^{-9} \text{ henries} \quad (50)$$

where

b = width of tape in centimeters

$\ln R = \ln b - (3/2)$ as for (46)

$$\ln R_n = \frac{(n+1)^2}{2} \ln(n+1)b - n^2 \ln nb + \frac{(n-1)^2}{2} \ln(n-1)b - \frac{3}{2}$$

in which n takes on values of one or larger. The letter n denotes the number of tape widths between the centers of the tapes shown in Fig. 20. For n greater than one, $\ln R_n$ can be calculated from¹⁰

$$\ln R_n = \ln n - \left[\frac{1}{12n^2} + \frac{1}{60n^4} + \frac{1}{168n^6} + \frac{1}{360n^8} + \frac{1}{660n^{10}} + \dots \right]. \quad (51)$$

To solve for the capacitance expression, we again use the relation given by (50) and obtain the expression for the total capacitance by the procedure given in Appendix II. The capacitance becomes

$$C = \frac{Kl \cdot 10^{-12}}{3.6 \ln \frac{R_n}{R}} \text{ farads} \quad (52)$$

Substituting into the expressions for $R = \sqrt{3L/C}$ and $\sqrt{5L/C}$, we obtain

$$R = \frac{207.8}{\sqrt{K}} \ln \frac{R_n}{R} \text{ ohms for low frequencies} \quad (53)$$

and

$$R = \frac{268.5}{\sqrt{K}} \ln \frac{R_n}{R} \text{ ohms for high frequencies.} \quad (54)$$

The frequency expression for this winding becomes

$$f = \frac{6.75 \cdot 10^{10}}{\sqrt{K} l} \text{ cycles per second.} \quad (55)$$

Figure 21 is a plot of the high-frequency expression with $n = 2$, $K = 3.22$ and different values of b .

An interesting case is found when $n = 1$ with the tapes not making contact. The expression for the inductance becomes¹⁰

$$L = 5.545l \cdot 10^{-9} \text{ henries} \quad (56)$$

and the capacitance is

$$C = 6.95Kl \cdot 10^{-14} \text{ farads} \quad (57)$$

whence

$$R = \frac{831.2}{\sqrt{K}} \text{ ohms for low frequencies} \quad (58)$$

and

$$R = \frac{1074}{\sqrt{K}} \text{ ohms for high frequencies.} \quad (59)$$

¹³ G. P. Harnwell, *Principles of Electricity and Electromagnetism*, 2nd ed. New York: McGraw-Hill, 1949.

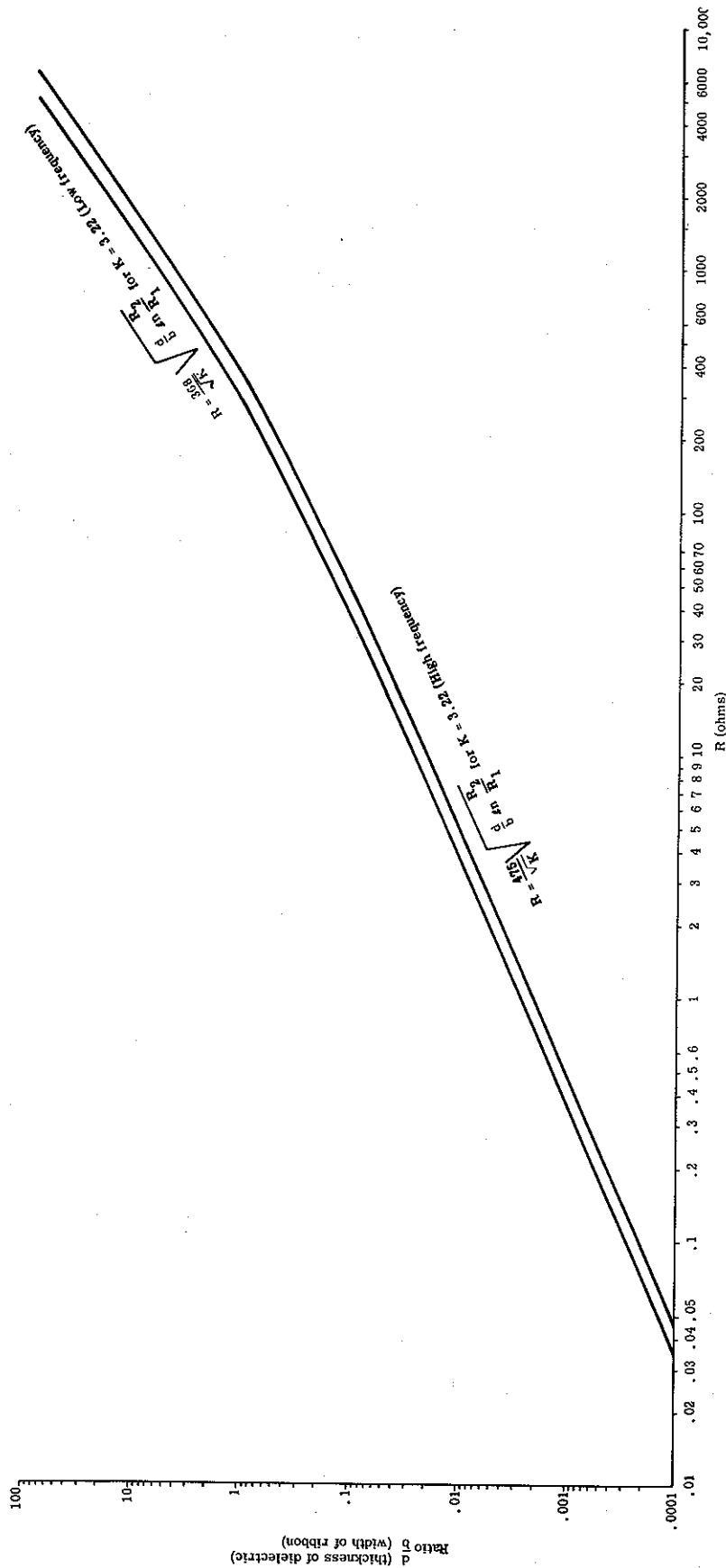

Fig. 19. Plot of formulas for winding nonreactive Chaperon resistors using ribbon conductors when ribbons are parallel.



Fig. 20. Relation of tape width b and distance between centers.

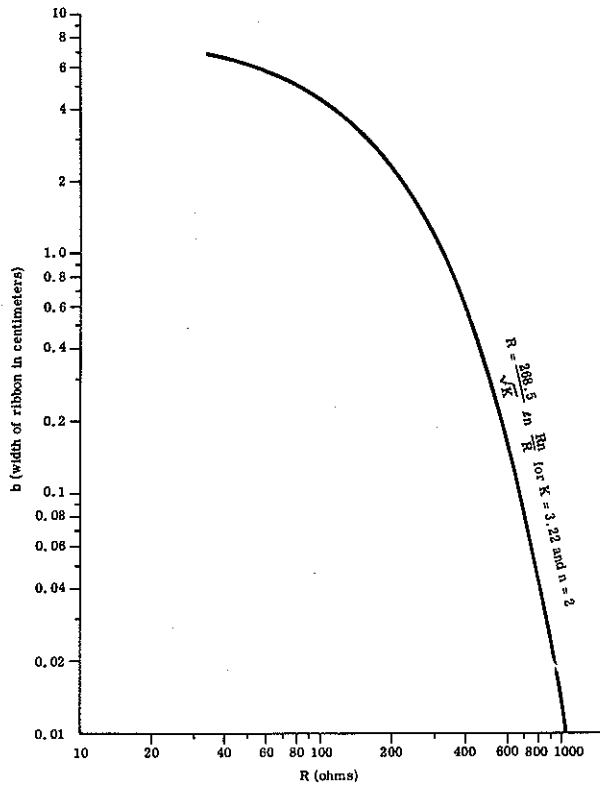

Fig. 21. Plot of formula for winding nonreactive chaperon resistors when ribbons are in the same plane.

Thus, the resistance is only a function of the dielectric constant of the material between the tapes. The frequency expression becomes

$$f = \frac{1.14 \cdot 10^{10}}{\sqrt{K} l} \text{ cycles per second.} \quad (60)$$

Equations (50)–(60) are directly applicable to thin film resistors deposited upon flat substrates. Equations (50), (52) give the inductance and capacitance of lead wires on printed-circuit boards; when the wires form return circuits.

Figure 17(b) is an arrangement whose capacitance varies between that of (a) and (c). Although the expressions for the inductance and capacitance were not available for this paper, resistors have been made with acceptable frequency responses. By placing each turn of the coils as closely together as possible without making contact, and by using tapes whose widths are suggested by (a), low-inductance resistors can be made (see Table II).

Figure 22 is a photograph of a relatively low-reactance resistor of 600 ohms, wound on a cylindrical core, using ribbon conductors. It is Sample 2 of Table II, showing the constructional data of three units. Table II is a record of the building of the resistors to have a minimum reactance for a $1\frac{1}{2}$ -million volt pulse.

Samples 1 and 2 show that the residual inductance was reduced by placing the coils closer together with the thinner dielectric. Sample 3 was made with a higher resistivity ribbon; hence, both the inductance and capaci-

tance were reduced. These results are indicated by the reduction in the residual inductance.

The frequency response of each resistor is shown in Fig. 23. Again, Sample 3 has the best frequency response. It can be further improved by using a wider ribbon and by decreasing the dielectric thickness.

The "Hairpin" or Loop Resistor Using Round Wire

The hairpin resistor approaches Fig. 1, used in developing the relations between R , L , and C . With round wire, the inductance is

$$L = 4l \left(\ln \frac{d}{r} + \frac{1}{4} \right) \cdot 10^{-9} \text{ henries} \quad (61)$$

from (37), and from (38),

$$C = \frac{Kl \cdot 10^{-12}}{3.6 \ln \frac{d}{r}} \text{ farads.} \quad (62)$$

Therefore, the expressions for the resistance become

$$R = \frac{208}{\sqrt{K}} \sqrt{\left(\ln \frac{d}{r} \right)^2 + \frac{1}{4} \ln \frac{d}{r}} \text{ ohms for low frequencies} \quad (63)$$

and

$$R = \frac{268.5}{\sqrt{K}} \sqrt{\left(\ln \frac{d}{r} \right)^2 + \frac{1}{4} \ln \frac{d}{r}} \text{ ohms for high frequencies.} \quad (64)$$

These expressions are the same as those for the Chaperon winding, (39) and (40). Figure 7 shows plots of R as a function of d/r .

When the ratio of d/r becomes less than 10, the expressions for R must be changed, as was done with the Chaperon winding; hence,

$$R = \frac{208}{\sqrt{K}} \sqrt{\left(\cosh^{-1} \frac{d}{2r} \right)^2 + \frac{1}{4} \cosh^{-1} \frac{d}{2r}} \text{ ohms for low frequencies} \quad (65)$$

and

$$R = \frac{268.5}{\sqrt{K}} \sqrt{\left(\cosh^{-1} \frac{d}{2r} \right)^2 + \frac{1}{4} \cosh^{-1} \frac{d}{2r}} \text{ ohms for high frequencies.} \quad (66)$$

Plots of these expressions were given in Fig. (8).

For the expression $f = 1/\pi \sqrt{1/2LC}$, we substitute (61) and (62) for L and C , and obtain

$$f = \frac{6.75 \cdot 10^{10}}{l \sqrt{K}} \sqrt{\frac{\ln \frac{d}{r}}{\ln \frac{d}{r} + \frac{1}{4}}} \text{ cycles per second.}$$

The length of the conductors is $R/2\rho$. For proximity effects, $\cosh^{-1} d/2r$ is substituted for $\ln d/r$.

TABLE II
CONSTRUCTIONAL DATA ON THREE CHAPERON RESISTORS USING WIRE RIBBON

Sample No.	DC resistance (ohms)	Width of ribbon (inch)	Thickness of ribbon (inch)	Resistivity (ohms/cm ft)	Thickness of dielectric (inch)	Length of coils (inches)	Residual inductance at 200 kc (microhenries)
1	610	0.0156	0.003	11.19	0.011	10	2.37
2	606	0.0156	0.003	11.19	0.005	10	1.25
3	601	0.0156	0.002	18	0.005	5	0.54

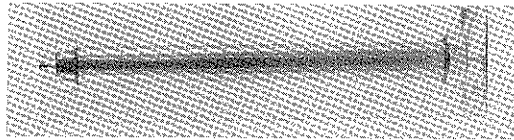

Fig. 22. A low-reactance, 600-ohm, 1 1/2 million-volt pulse resistor using wire ribbon conductors wound in the Chaperon manner on a cylindrical core.

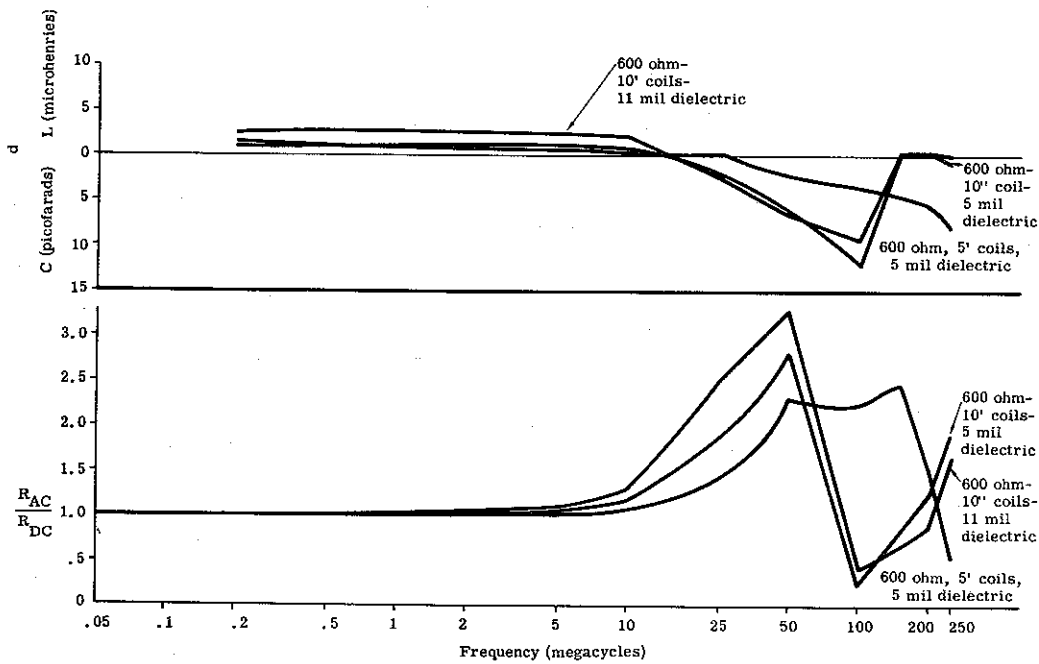

Fig. 23. Frequency responses of three resistors wound in the Chaperon manner with wire ribbon and using different dielectric thickness.

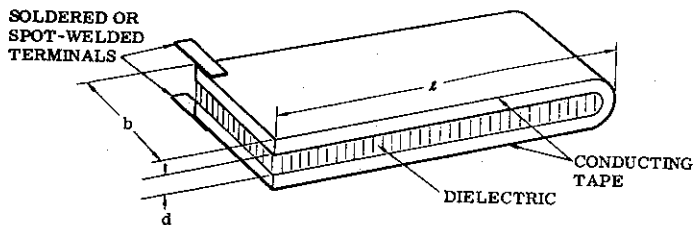

Fig. 24. The hairpin nonreactive resistor using wire ribbon.

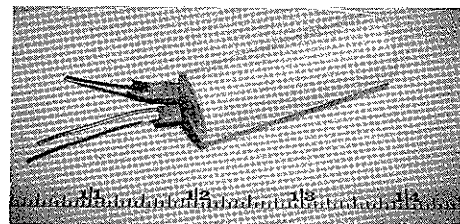

Fig. 25. An essentially zero reactance resistor of 0.9 ohm, made from the hairpin winding using ribbon wire.

The "Hairpin" or Loop Winding, Using Ribbon Conductors

For low-resistance values, the use of ribbon or tape conductors for the loop resistor offers many advantages. The expression for the inductance, using Fig. 24, is

$$L = 4l \ln \frac{R_2}{R_1} \cdot 10^{-9} \text{ henries} \quad (68)$$

and

$$C = \frac{8.85Klb \cdot 10^{-14}}{d} \text{ farads} \quad (69)$$

where the terms are the same as for the Chaperon winding, (46) and (47). Again, the expressions for the resistance become

$$R = \frac{368}{\sqrt{K}} \sqrt{\frac{d}{b}} \ln \frac{R_2}{R_1} \text{ ohms for low frequencies,} \quad (70)$$

and

$$R = \frac{475}{\sqrt{K}} \sqrt{\frac{d}{b}} \ln \frac{R_2}{R_1} \text{ ohms for high frequencies.} \quad (71)$$

Plots of this expression were shown in Fig. (19).

The frequency expression in terms of the conductors from $f = 1/\pi \sqrt{1/2LC}$ becomes

$$f = \frac{1.195 \cdot 10^{10}}{\sqrt{K} l} \sqrt{\frac{d}{b \ln \frac{R_2}{R_1}}} \text{ cycles per second.} \quad (72)$$

The length of the conductors is $R/2\rho$.

Figure 25 shows a loop resistor made from Tophet C wire ribbon, 1.75 inches wide by 0.001 inch thick, of 0.306 ohm per foot, and a separation of 0.005 inch. These dimensions gave a d/b ratio of 0.0028, corresponding to a 1.4-ohm unit from the high-frequency plot in Fig. 19. The dc resistance was slightly less, 0.9 ohm, but still there was essentially zero reactance at 200 kilocycles. After encapsulation, the reactance became capacitive, 0.01 picofarad, approximately. The effect of the lead wires and the position of the resistor terminals to the high-voltage terminal of the bridge masked the true reading of reactance. A 14-kilovolt pulse produced an arc breakdown at the beginning of the ribbons. Removal of any sharp edges and an increase in the resistance should improve the voltage breakdown.

Coaxial Pulse Resistor Using Round Wire

Pulse resistors can also be made in the coaxial form using the return circuit with one end shorted. The open circuited end then forms the terminals.

For the return circuit shown in Fig. 26, the expression for the inductance is¹⁰

$$L = 2l \ln \frac{r_2}{r_1} \cdot 10^{-9} \text{ henries} \quad (73)$$

and the capacitance is, from the method in Appendix II,

$$C = \frac{0.556Kl}{\ln \frac{r_2}{r_1}} \cdot 10^{-12} \text{ farads} \quad (74)$$

where

- K = dielectric constant of material between the inner and outer conductors
- r_1 = radius of inner conductor in centimeters
- r_2 = radius of outer conductor in centimeters
- l = length in centimeters.

Then the expressions for the resistance become, from $R = \sqrt{3L/C}$ and $\sqrt{5L/C}$,

$$R = \frac{108}{\sqrt{K}} \ln \frac{r_2}{r_1} \text{ ohms for low frequencies} \quad (75)$$

and

$$R = \frac{134}{\sqrt{K}} \ln \frac{r_2}{r_1} \text{ ohms for high frequencies.} \quad (76)$$

The predictable frequency from $f = 1/\pi \sqrt{1/2LC}$ becomes

$$f = \frac{6.76 \cdot 10^9}{l\sqrt{K}} \text{ cycles per second.}$$

Plots of (75) and (76) are given in Fig. 27. As with the other geometries, a small change in the ratio of the inner and outer diameters results in a large change in the nonreactive resistor.

The above formulas are based upon the assumption that both the inner and outer conductors are made of the same resistive material. Thus, the distributed resistance, inductance, and capacitance are consistent throughout. The conductors should be tubes of the resistive material to give the best results from the formulas.

At this time, the author has also used the coaxial form to reduce the residual inductance of a cylindrical Chaperon-wound resistor with it as the center conductor. Under these conditions, the capacitance of the outer conductor (usually copper) can be considered additive to that of the Chaperon winding, since it is distributed uniformly along the length of the resistor. However, the current distribution will not remain uniform with increasing frequency, since the resistivities of the inner and outer conductors differ.

To calculate the radius of the shield, we proceed as follows:

The residual inductance, L_R , of the resistor by itself, is from (34),

$$L_R = L - \frac{CR^2}{5} \quad (77)$$

where L and C are the values given for the Chaperon winding in the section, *Mathematical Development Relating R, L, and C of the Resistor*. To make L_R equal to zero, we have, by adding the capacitance of the shield,

$$0 = L - \frac{(C + C_{\text{shield}})R^2}{5} \quad (78)$$

Solving these equations for the capacitance of the shield,

CONSTRUCTION AND MEASURING TECHNIQUES

The major precautions one should follow in building the pulse resistors are:

- 1) For every resistor geometry, one must use a lathe or winding machine to maintain the separation and size of the conductors throughout the lengths of the conductors. This assures that the resistor's geometry follows the design formula and preserves the relation of the resistance, inductance, and capacitance per unit length. The use of a matting, such as Dacron cloth or fiber, will insure the separation of the conductors wound on cards or cylindrical forms.
- 2) The winding form, such as nylon or epoxy glass board, should have a high volume and surface breakdown. It also must be clean and permit good bonding of the encapsulating material. Cracks or surface scratches should be avoided.
- 3) The encapsulating material should bond the form and the wires throughout. It must completely penetrate the matting between the conductors. Encapsulation methods must insure that no bubbles or uncured portions remain in the finished unit.
- 4) The resistor terminals must be free of all fluxes, whether soldered or silver brazed, which may have been used to secure the ends of the conductors. The terminals must be secured to the form so that they will support the resistor during encapsulation. Corona shields must allow the encapsulation material to penetrate and bond to their total surfaces. These should be polished to the degree produced by a rouge polishing agent.

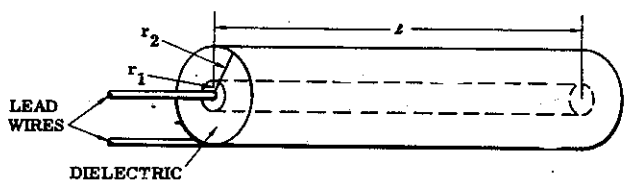

Fig. 26. Coaxial pulse resistor connected as a return circuit.

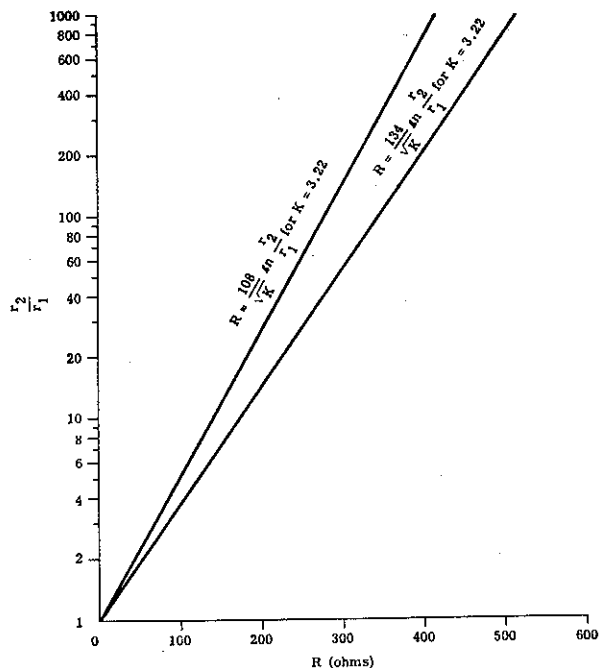

Fig. 27. Plot of ratio of outer and inner radii with resistance value for making nonreactive resistors from a coaxial return circuit.

we have

$$C_{\text{shield}} = \frac{5(2L - L_R)}{R^2} \text{ farads.} \quad (79)$$

Setting (74) equal to this expression, we obtain, for the radius of the shield,

$$r_2 = r_1 \exp \left[\frac{0.111KL \cdot 10^{-12} R^2}{2L - L_R} \right] \text{ centimeters,} \quad (80)$$

where \exp is $2.718 \dots$, the base of the natural logarithms, and r_1 is the radius of the original resistor.

Equation (80) shows that r_2 is large when $2L - L_R$ is small, i.e., less capacitance is required when the residual inductance of the original resistor is small. This result is expected.

The use of the coaxial resistor to compensate for a previously inductive resistor should be restricted to residual inductances less than 0.5 microhenry. The nonuniform current distribution at the higher frequencies in a pulse will distort the current waveform. However, in the case where a short length of high-resistive wire is used for the center conductor, the effect becomes very small. It is most applicable for low-resistance values so that the length of the center conductor is only 1 or 2 inches long.

Figure 28 is a photograph of an encapsulated resistor having gas bubbles produced during curing of the epoxy. Such defects readily produce corona discharges and a permanent voltage breakdown.

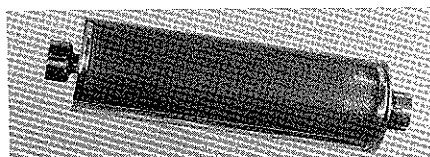

Fig. 28. A Chaperon-wound resistor of 15 kilohms, 150-kilovolt pulse voltage, showing gas bubbles from a contaminant on the windings.

Test Equipment

The pulse resistors were measured with two different pieces of equipment.

- 1) An RLC bridge made by Bell Laboratories.
- 2) The RX meter, Model 250A, made by Boonton Electronics Corporation.

The RLC bridge covers a frequency range from 0.2 to 200 kilocycles. It measures resistance from 0 to 11110 ohms, inductance from 0 to 11110 microhenries, capacitance from 0 to 11110 picofarads, and conductance

from 0 to 11110 micromhos. The zero ranges are realized, since the readings for zero setting the bridge are always subtracted from those read for a resistor. At balance, the sensitivity of the bridge approaches 10 microvolts (0.001 microhenry) and permits a precise adjustment to obtain the five digit accuracy. Corrections are provided for the ranges of the instrument. The bridge readily measures different shorting bars used for inductance measurements.

The RX meter covers the frequency range of 0.5 to 250 megacycles, with a resistance range of 15 to 1000 00 ohms. The capacitance range is 0 to 20 picofarads, and the inductance ranges from 0.01 microhenry to 100 millihenries, depending upon the frequency setting.

Measuring Techniques

Although the formulas for pulse resistors will assure very small time constants, measuring their values presents many difficulties. Both the resistance value and the physical size adversely affect the measurements.

The inductance of the lead wires adds to the resistor's residual inductance for values below 1000 ohms. Above 1000 ohms, capacitance problems predominate. Large resistors have an appreciable ground capacitance, while with small resistors an exact location of the terminals is required from which to measure their reactance. The combination of resistance value and physical size compounds the measuring procedures.

For both instruments, precautions must be observed for resistors having time constants of 10^{-8} seconds or less:

- 1) Although the effect of the resistor's capacitance to a ground plane is subtracted from the readings, its distributed portion to the windings changes the frequency response. This capacitance is minimized by removing a cylindrical resistor at least one diameter from the ground plane. A flat resistor is rotated so that a longitudinal edge is presented to the ground plane. The larger the resistor body, the greater is this capacitance effect.

- 2) The length, size, and shape of the lead wires also affect the residual reactance by becoming a part of the resistor's parameters. They must be as short as possible and have a minimum of inductance.

- 3) A nearly zero reactance unit produces essentially no coupling to external objects. However, the physical position of the resistor must remain constant throughout the frequency range of the instrument. Any change in position will affect the capacitance to the ground plane. Further, as mentioned, the selected position of the terminals must be repeated each time a resistor is measured. Otherwise, the error in measurement will far exceed the resistor's reactance.

Resistors having time constants greater than 10^{-8} seconds present coupling to external objects. The effect becomes extreme with large resistors and at frequencies above one megacycle. The large resistors require a minimum coupling position to a ground plane although some cases cannot be improved.

Although the instruments have sufficient accuracy, the operator must adjust the measuring setup to minimize the effects external to the resistor so that the instrument accuracy can be obtained.

FREQUENCY EFFECTS

Fourier Analysis of Pulse Frequencies

For extremely high voltage pulses, the pulse is considered to be rectangular and of only a single polarity. We shall discuss such a pulse (see Fig. 29).

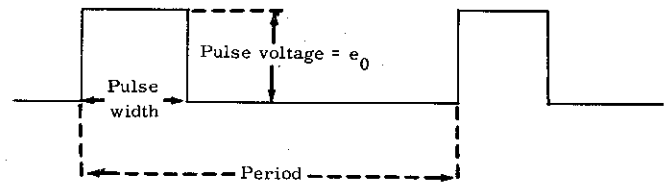

Fig. 29. Rectangular pulse waveform.

Kerchner and Corcoran¹⁴ give the Fourier expression for this pulse as

$$e = A_1 \sin \omega t + \frac{A_1}{3} \sin 3\omega t + \frac{A_1}{5} \sin 5\omega t + \dots \quad (81)$$

where

$$A_1 = \frac{4e_0}{\pi}$$

and

$$\omega = 2\pi \cdot \text{frequency.}$$

The frequency of the fundamental is related to the pulse width w by

$$f = \frac{1}{2}w \text{ cycles per second.} \quad (82)$$

If w is in microseconds, then the frequency becomes

$$f = \frac{5 \cdot 10^5}{w} \text{ cycles per second.} \quad (83)$$

For the resistors described in this paper, the pulse width varies nominally from 0.1 to 20 microseconds. Thus, the fundamental frequency varies from 5 megacycles down to 25 kilocycles.

To determine the upper frequency to which the resistor must be nonreactive, we can make an estimate of the frequencies necessary to reproduce the rectangular pulse shape, including the rise time of the leading edge. The frequency of the sine wave to approximate a rise time t is the reciprocal of $4t$.

This estimate suggests harmonics varying from the tenth through the twenty-fifth. When the rise time of the leading edge is 10^{-9} seconds, then the maximum frequency is 250 megacycles. At this frequency, the skin

¹⁴ R. M. Kerchner and G. F. Corcoran, *Alternating Current Circuits*, 3rd ed. New York: Wiley, 1955, chs. 6, 12, p. 171.

effect on the conductors, including the inductance and the capacitance, must be compensated. These topics compose the next two sections.

Skin Effect on Resistance and Inductance

Having frequencies in the region of 200 megacycles, we must consider the skin effect, which results from nonuniformity of the current distribution. As the frequency increases from dc, the current through solid conductors gradually concentrates toward the outer surface of the conductor. This action is brought about by the increased inductance of inner portions of the conductor. The increase can be seen from the high-frequency expression for the inductance of a rod,

$$L = 2l \ln \left(\frac{2l}{r} - 1 \right) \cdot 10^{-9} \text{ henries,} \quad (84)$$

where l is the length, and r is the radius of the rod. As r increases from the center, the inductance decreases; hence, as the frequency increases, the impedance increases at the center more than it does at the outer parts of the wire. Thus, the current recedes to the outer radius of the wire. This action results in an increase in the resistance, since the current's cross section is reduced.

The ratio of the ac resistance to the dc resistance is given by the following expression:¹⁹

$$\frac{R_{AC}}{R_{DC}} = \frac{\pi r}{\sqrt{2}} \sqrt{\frac{2 \cdot f}{\rho}} = \frac{\pi D}{2\sqrt{2}} \sqrt{\frac{2f}{\rho}} \quad (85)$$

where r is the radius, D is the diameter, and ρ is the resistivity in absolute units of the conductor. The term f is the frequency in cycles per second.

We can calculate the frequency for any conductor so that the ac resistance will not be greater than one percent of the dc resistance value. Substituting in (96), we obtain

$$\frac{R_{AC}}{R_{DC}} = 1.01 = \frac{\pi D}{2\sqrt{2}} \sqrt{\frac{2f}{\rho}} \quad (86)$$

Solving for f , we have

$$f = \frac{0.408 \cdot \rho}{D^2} \text{ cycles per second.} \quad (87)$$

For a frequency of 100 megacycles and resistivity of $1.32 \cdot 10^8$ abohms per centimeter for Evanohm wire (for copper, 1721 abohms per centimeter, the diameter of the largest wire that can be used becomes

$$D = \sqrt{\frac{0.408 \cdot \rho}{f}} \quad (88)$$

Upon substituting for ρ and f , we find

$$D = \sqrt{\frac{0.408 \cdot 1.32 \cdot 10^8}{10^8}} = 0.0232 \text{ centimeters.} \quad (89)$$

In actual practice, the peak currents may require a larger wire diameter to prevent overheating the wire. The depth of penetration as a function of frequency

and the resistivity is¹⁵

$$y = \frac{1}{2\pi} \sqrt{\frac{\rho}{f}} \text{ centimeters} \quad (90)$$

For $f = 100$ megacycles and $\rho = 1.32 \cdot 10^8$, we obtain

$$y = \frac{1}{6.28} \sqrt{\frac{1.32 \cdot 10^8}{10^8}} = 0.0056 \text{ centimeters.} \quad (91)$$

Table III presents the effect of frequency on Evanohm, Tophet A, and Manganin wire. For frequencies of 100, 200, and 400 megacycles, the largest wire diameter and the depth of penetration were calculated for a one percent increase in the dc resistance.

The effect of frequency on the inductance of the conductors can be shown by the change in the inductance formula for a solid conductor. At low frequencies, the inductance is

$$L = 2l \left[\ln \frac{2l}{r} - 1 + \frac{\mu T}{4} \right] \cdot 10^{-9} \text{ henries} \quad (92)$$

where l is the length and r is radius of the conductor in centimeters. T is a function given by Grover.¹² For resistance wire, μ , the magnetic permeability, is essentially unity. The formula then becomes

$$L = 2l \left[\ln \frac{2l}{r} - 1 + \frac{T}{4} \right] \cdot 10^{-9} \text{ henries.} \quad (93)$$

As the frequency is increased, the current, upon concentrating towards the surface, causes a loss of the flux produced by the portion that flowed in the center of the conductor. As Grover shows, T becomes zero at very high frequencies, so the formula becomes

$$L = 2l \left[\ln \frac{2l}{r} - 1 \right] \cdot 10^{-9} \text{ henries.} \quad (94)$$

This slight reduction in the inductance can be ignored by using all high-frequency formulas in making pulse resistors as was done in the section, "Design Formulas For Pulse Resistors of Different Geometries."

Frequency Effect on the Dielectric Material

As Attwood shows in his text,¹⁶ the dielectric constant decreases with increasing frequency, since the polarization of the bound charges cannot follow the rapid reversal of the electric field at high frequencies. The change in the dielectric constant and the dissipation factor of SRIR with frequency are shown in Table IV. The dissipation factor is defined as the ratio of the equivalent series resistance to the impedance of a capacitor having the dielectric.

To show the effect on frequency response of the pulse resistors, we proceed as follows.

Race and Larrick¹⁵ show that $(j\omega c + g)$ of the general expression $\sqrt{(\rho + j\omega\lambda)(j\omega c + g)}$ in (6) of the section,

¹⁵ H. H. Race and C. V. Larrick, "High-frequency coaxial line calculations," *Elec. Engrg.*, vol. 61, pp. 526-530, July 1942.

¹⁶ S. S. Attwood, *Electric and Magnetic Fields*, 2nd, 3rd eds. New York: Wiley, 1941, 1949.

TABLE III
FREQUENCY EFFECTS ON DIFFERENT KINDS OF RESISTANCE WIRE

Name and composition	Resistivities abohms/cm	Highest frequency for 1% change in resistance	Depth of penetration		Largest wire diameter		
		megacycles	cm	inch	cm	inch	#AWG
Evanohm 74.5% Ni 20% Cr 2.75% Al 2.75% Cu	1.32 · 10 ⁶	100	0.0056	0.002	0.023	0.009	31
		200	0.0039	0.0015	0.0162	0.006	34
		400	0.0028	0.001	0.011	0.0045	37
Tophet A 80% Ni 20% Cr	1.08 · 10 ⁶	100	0.0052	0.002	0.021	0.008	32
		200	0.0037	0.0014	0.015	0.0057	35
		400	0.0026	0.001	0.010	0.004	38
Manganin 87% Cu 13% Mn	4.81 · 10 ⁴	100	0.0035	0.0014	0.014	0.0055	35
		200	0.0024	0.0009	0.010	0.0039	38
		400	0.0017	0.0007	0.007	0.0027	41

TABLE IV
CHANGES IN THE DIELECTRIC CONSTANT AND DISSIPATION FACTOR OF SRIR EPOXY WITH FREQUENCY

Frequency	10 ²	10 ³	10 ⁴	10 ⁵	10 ⁶	10 ⁷ (cps)
Dielectric constant	3.64	3.55	3.54	3.42	3.42	3.22
Dissipation factor	0.0167	0.0161	0.0160	0.0191	0.0130	0.0206

"Principles of Transmission Lines Applied to Pulse Resistors," can be expressed

$$j\omega c + g = \omega C_v(K' + jK) \quad (95)$$

where C_v is the capacitance per unit length with air as the dielectric, K is the dielectric constant, and K' is the loss factor, $g/\omega C_v$. Expanding the right side of (95), we have

$$j\omega c + g = \omega C_v K' + j\omega C_v K. \quad (96)$$

Equating the real and imaginary parts, we obtain

$$j\omega c = j\omega C_v K \quad \text{or} \quad c = C_v K \quad (97)$$

and

$$g = \omega C_v K'. \quad (98)$$

Since the capacitance, C_v , for the geometry of each resistor is known, we can express g in terms of the frequency, the capacity, and the loss factor.

Substituting for C_v , the capacitance per unit length for the Chaperon winding of (38), we have

$$g = \frac{\omega K' \cdot 10^{-12}}{3.6 \ln \frac{d}{r}} = \frac{1.745j \cdot K' \cdot 10^{-12}}{\ln \frac{d}{r}} \text{ mhos per centimeter.} \quad (99)$$

Therefore, substituting in (96), we have

$$j\omega c + g = j\omega \frac{K \cdot 10^{-12}}{3.6 \ln \frac{d}{r}} + \frac{\omega K' \cdot 10^{-12}}{3.6 \ln \frac{d}{r}}. \quad (100)$$

TABLE V
DIELECTRIC CONSTANT AND LOSS FACTOR OF KEL F 500 AT DIFFERENT FREQUENCIES

Frequency	10 ⁶	10 ⁷	10 ⁸ (cps)
Dielectric constant	2.27	2.33	2.37
Loss factor	0.0082	0.0078	0.0048

Removing common factors, we have

$$j\omega c + g = \left(j + \frac{K'}{K} \right) \frac{\omega K \cdot 10^{-12}}{3.6 \ln \frac{d}{r}}. \quad (101)$$

To make the assumption that $g = 0$ for the development of the general expression for the impedance of the pulse resistor, (25), the ratio K'/K should be less than 0.1. However, since the losses increase with frequency, then the capacitance increases and eventually will cause the residual reactance of a resistor to become capacitive. To prevent this effect we must use dielectrics whose losses are small at extremely high frequencies.

As the demands on the pulse resistors become more restrictive on the size, voltage, and frequency response, new dielectrics will need to be studied. Such a material is Kel F 500 used in high-frequency, high-voltage RF cables. Its dielectric constant and loss factor are given in Table V.

The frequency stability of this material is readily seen.

CONCLUSIONS

This paper has presented design formulas for high-voltage pulse resistors using both round wire and ribbon conductors. The return circuit, treated as a short-circuited transmission line, formed the basis for relating the distributed resistance, inductance, and capacitance. The pulse resistor differs from the normal lossless transmission line by dissipating all of the pulse energy in an efficient way over the length of the conductors. When the resistor has no residual reactance, no coupling is presented to external objects.

The residual reactance was expressed as follows:

Residual Reactance

$$= L - (CR^2/3) \text{ for low frequencies}$$

and

Residual Reactance

$$= L - (CR^2/5) \text{ for higher frequencies.}$$

The residual reactance becomes zero when $R = \sqrt{3L/C}$ or $\sqrt{5L/C}$ ohms. The higher value expression occurs at the frequency $f = 1/\pi \sqrt{1/2LC}$ cycles per second.

Upon substituting expressions for the inductance L and the capacitance C for different geometries, an expression for the resistance is obtained which is not a function of the length of the conductors. The expressions for R , L , and C , control the values per unit length of the return circuit and thereby ignore the winding form. The spacing and size of the conductors must be maintained throughout the length of the conductors. The method was applied to the Chaperon double winding, the loop or hairpin unit and the coaxial form.

The theoretical or ideal resistor cannot always be realized. Wire sizes must be increased to prevent overheating, and the resistor's physical dimensions become restricted to meet the equipment requirements.

Resistance values can vary from one ohm to a few hundred thousand ohms, with the low values tending to be inductive, and the high values capacitive. However, these effects are reduced by selecting the correct resistor geometry and the form of the conductors. Time constants vary from 10^{-6} to 10^{-10} seconds.

The effect of frequency on the resistance, inductance, and capacitance can be controlled by using high-resistivity wire, high-frequency formulas, and stable dielectric materials.

Pulse voltages up to 1.2 million volts have been applied successfully to units with corona shields on the terminals and with the resistors encapsulated in epoxy resin.

The resistors are directly applicable as dummy antennas for continuous waves.

APPENDIX I

EXPANSION OF THE RETURN CIRCUIT IMPEDANCE

From (24), we have

$$\begin{aligned} Z &= (R + j\omega L) - \frac{1}{3}(R + j\omega L)^2(j\omega C + G) \\ &\quad + \frac{2}{15}(R + j\omega L)^3(j\omega C + G)^2 \\ &\quad - \frac{17}{315}(R + j\omega L)^4(j\omega C + G)^3 \dots \quad (102) \end{aligned}$$

Setting $G = 0$ and expanding the first three terms, we obtain

$$\begin{aligned} Z &= R + j\omega L - \frac{1}{3}[(R^2 + j2\omega RL - \omega^2 L^2)(j\omega C)] \\ &\quad + \frac{2}{15}[(R^3 + j3\omega R^2 L - 3\omega^2 L^2 R - j\omega^3 L^3)(-\omega^2 C^2)]. \quad (103) \end{aligned}$$

Removing the parentheses inside the brackets, we have

$$\begin{aligned} Z &= R + j\omega L - \frac{1}{3}[jR^2\omega C - 2\omega^2 RLC - j\omega^3 L^2 C] \\ &\quad + \frac{2}{15}[-R^3\omega^2 C^2 - j3\omega^3 R^2 LC^2 + 3\omega^4 RL^2 C^2 + j\omega^5 L^3 C^2]. \quad (104) \end{aligned}$$

Removing the brackets, we have

$$\begin{aligned} Z &= R + j\omega L - j\frac{R^2\omega C}{3} + \frac{2}{3}\omega^2 RLC + j\frac{\omega^3 L^2 C}{3} \\ &\quad - \frac{2}{15}R^3\omega^2 C^2 - j\frac{2}{5}\omega^3 R^2 LC^2 + \frac{2}{5}\omega^4 RL^2 C^2 + j\frac{2}{15}\omega^5 L^3 C^2. \quad (105) \end{aligned}$$

Collecting the real and imaginary terms, we obtain

$$\begin{aligned} Z &= R + \frac{2}{3}\omega^2 RLC - \frac{2}{15}R^3\omega^2 C^2 + \frac{2}{5}\omega^4 RL^2 C^2 \\ &\quad + j\left(\omega L - \frac{\omega R^2 C}{3} + \frac{\omega^3 L^2 C}{3} - \frac{2}{5}\omega^3 R^2 LC^2 + \frac{2}{15}\omega^5 L^3 C^2\right). \quad (106) \end{aligned}$$

Dropping the last term of the real part and the last two terms of the imaginary expression, which means that we are only using the first six terms of the expansion, we obtain

$$\begin{aligned} Z &= R \left[1 + 2\omega^2 C \left(\frac{L}{3} - \frac{R^2 C}{15} \right) \right] \\ &\quad + j\omega \left[L - \frac{R^2 C}{3} + \frac{\omega^2 L^2 C}{3} \right]. \quad (107) \end{aligned}$$

Setting the term in parentheses of the real part, and that in the brackets of the imaginary portion, to zero, we have

$$\frac{L}{3} - \frac{R^2 C}{15} = 0, \text{ hence, } R = \sqrt{5 \frac{L}{C}} \quad (108)$$

and

$$L - \frac{R^2 C}{3} + \frac{\omega^2 L^2 C}{3} = 0, \text{ hence,}$$

$$R = \sqrt{\frac{3L}{C} + \omega^2 L^2} = \sqrt{\frac{L}{C} (3 + \omega^2 LC)}. \quad (109)$$

From the two expressions, we see that

$$5 = 3 + \omega^2 LC \text{ or, } \omega^2 LC = 2,$$

hence,

$$f = \frac{1}{\pi} \sqrt{\frac{1}{2LC}}. \quad (110)$$

Utilizing all of the terms in (106) above and factoring out common terms, we have

$$Z = R \left[1 + \frac{2}{3} \omega^2 LC - \frac{2}{15} R^2 \omega^2 C^2 + \frac{2}{5} \omega^4 L^2 C^2 \right]$$

$$+ j\omega \left[L - \frac{R^2 C}{3} + \frac{\omega^2 L^2 C}{3} - \frac{2}{5} \omega^2 R^2 LC^2 + \frac{2}{15} \omega^4 L^3 C^2 \right]. \quad (111)$$

Rewriting further, we have

$$Z = R \left[1 + 2\omega^2 C \left(\frac{L}{3} - \frac{R^2 C}{15} + \frac{\omega^2 L^2 C}{5} \right) \right]$$

$$+ j\omega \left[L - R^2 \left(\frac{C}{3} + \frac{2}{5} \omega^2 LC^2 \right) + \omega^2 L^2 C \left(\frac{1}{3} + \frac{2}{15} \omega^2 LC \right) \right]. \quad (112)$$

APPENDIX II

RELATION OF INDUCTANCE AND CAPACITANCE OF A TRANSMISSION LINE

From transmission line theory when $LG = RC$, the inductance and capacitance per unit length are related as follows:⁶

$$\frac{1}{\sqrt{\lambda c}} = \frac{\text{velocity of light in centimeters per second}}{\sqrt{K}} \quad (113)$$

where λ and c are values per unit length.

Dividing the inductance of (50) by l , substituting the expression for λ , and then solving (113) for c , we have

$$c = \frac{K}{(\text{velocity})^2 4 \ln \frac{R_2}{R_1} \cdot 10^{-9}}. \quad (114)$$

Using $3 \cdot 10^{10}$ for the velocity of light and multiplying by l we have, for the total capacitance,

$$C = \frac{Kl \cdot 10^{-12}}{3.6 \ln \frac{R_2}{R_1}} \text{ farads.} \quad (115)$$

ACKNOWLEDGMENT

Appreciation is extended to co-workers: H. L. Floyd, Jr. and to F. V. Wyatt for their help in verifying the mathematical development and the many formulas, and to C. M. Barnes for constructing experimental models, designing terminations, and making the many measurements.

Reprinted from IEEE TRANSACTIONS ON PARTS, MATERIALS AND PACKAGING

Vol. PMP-1, Number 2, September 1965

Pp. 3-23

Copyright 1965, and reprinted by permission of the copyright owner

PRINTED IN THE U.S.A.